



# Addressable Analog Device Controller

## 3-AADC1



Complies to  
EN54 Part 2 and 4.

### Overview

The 3-AADC1 Addressable Analog Circuit Module is a local rail module used on the EST3 system. The module requires one connection on the rail chassis. The module can support 99 addressable analog sensors and 99 addressable analog modules. The controller also features a hinged front panel for a Control Display Module, which are available in a variety of LED and/or switch configurations. The 3-AADC1 is a direct replacement for the 3-AADC and 100% backward compatible.

The microprocessor based 3-AADC1 provides internal test and diagnostic functions for troubleshooting. The controller contains nonvolatile memory that stores the operating system software and data file which is downloaded from a PC. The System Definition Utility Program accomplishes data file programming including the device type, address, description, sensitivity, verification, and wiring configuration. The 3-AADC1 continuously checks the output value of each device, reporting status to the cabinet CPU. The module can isolate ground faults to a specific addressable loop.

All field wiring connections to the module are made via plug-in connectors, permitting termination of field wiring without the module installed in the enclosure. The plug-in connectors and snap rivet module mounting facilitate rapid remove and replace troubleshooting without the use of tools.

### Standard Features

- Class A (Style 7) or Class B (Style 4)
- Continuous monitoring of analog device values
- Ground fault detection by loop
- Removable field wiring terminals
- Fully backward compatible with the 3-AADC
- Listed for fire and security

# Application

The 3-AADC1 is ideal for EST3 systems being installed in retrofit applications where there is a quantity of existing analog devices installed. The 3-AADC1 is compatible with:

### Sensors

- 1551F ionization
- 2551F photoelectric
- 2551TF(B) photoelectric/thermal
- 5251F(B) thermal
- DH200PF photoelectric duct detector
- RZB12-6 Remote Zone Interface Module
- 1251F(B) ionization
- 2251F(B) photoelectric
- 5551F thermal
- 5551FR fixed/ROR thermal

### Modules

- M400MF(B) monitor
- M500CFS control
- M500XF isolator
- UIO-12 Universal Input/Output Module
- M501MF monitor
- M500SF control
- M500RF relay

NOTES: Relay bases, isolator bases, sounder bases, are NOT supported. The 3-AADC1 is fully backward compatible with the 3-AADC. When connecting RZB12-6 to 3-AADC1, a 3-RZBCAP is required at each RZB. Please refer to the latest RZB installation instructions (part number 387591).

The Addressable Analog circuit cable must be a minimum of 18 gauge twisted pair with 6 twists per foot. This cable may be unshielded or shielded as required. Shielded cable is recommended where electrical noise might interfere with data transmission. If shielded wire is used, it must be used through the entire length of the circuit. Distance limits are determined using the maximum allowable circuit resistance and capacitance, and manufacturer's cable specifications.

# Typical Wiring

## CLASS A WIRING

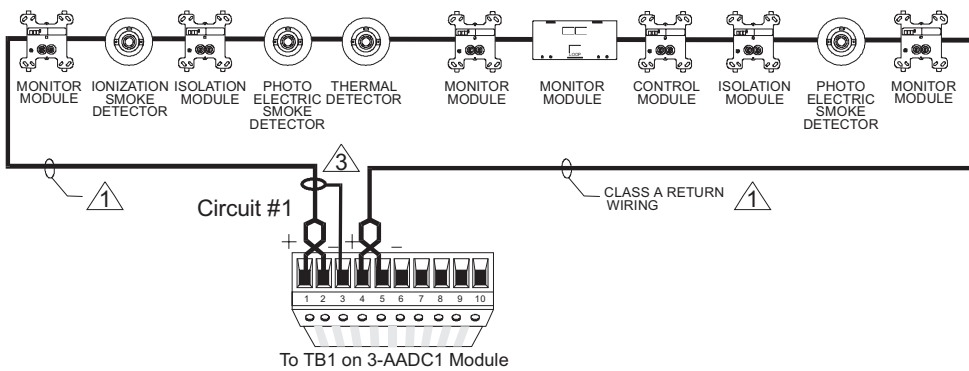

## CLASS B WIRING WITH T-TAP

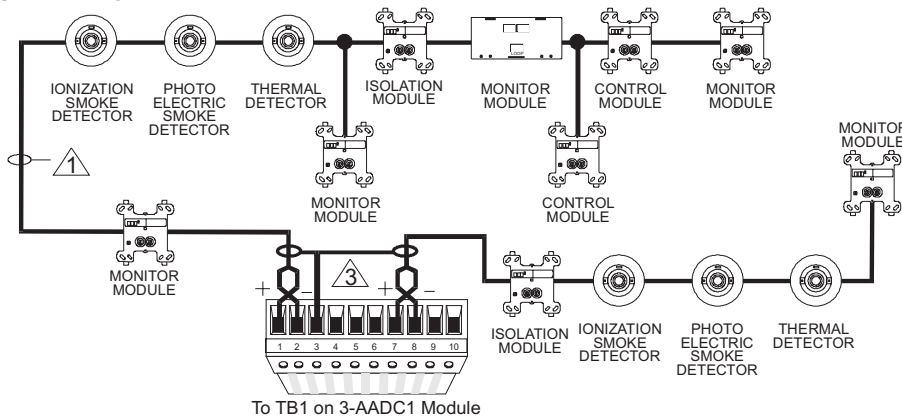

TB1  
3-AADC1  
ADDRESSABLE  
ANALOG  
CIRCUIT  
MODULE

### Wiring Notes

- 1 Maximum #12 AWG (2.5 mm<sup>2</sup>) wire; minimum #18 AWG (0.75 mm<sup>2</sup>) wire
- 2 Maximum wiring resistance 50 ohms, maximum wiring capacitance 0.5 µF
- 3 Shields (if used) must be continuous, insulated, and connected to Earth Ground only at the 3-AADC1 Module.
- 4 The analog addressable circuit does NOT support RZB 12-6's or UIO-12's
- 5 All wiring supervised and power limited

## Engineering Specification

The control panel shall provide an addressable analog interface module to directly connect to the existing addressable analog sensors and modules. The interface shall be capable of supporting 99 analog sensors and 99 input/control modules, and identifying

ground faults by loop. The module shall be capable of accommodating both Class A (Style 7) and Class B (Style 4) wiring. All field wiring terminations shall be made to removable connectors for ease of installation and troubleshooting.

## Specifications

Installation		1 LRM Space
Module Configuration		1 Addressable Analog Circuit
Operating Current*	Standby	175 mA
	Alarm	205 mA
Addressable Circuit Capacitance		0.5µF, max., all branches
Addressable Circuit Resistance		50 Ohms, max (NO RZB12-6 or UIO-12 modules or relay bases permitted) 36 Ohms when using RZB12-6 or UIO12 (No Relay bases permitted)
Addressable Circuit Configuration		Class A (Style 7) or Class B (Style 4)
Addressable Circuit Capacity	Sensors	99 sensors per circuit
	Modules	99 modules per circuit
Ground Fault Limits		10K Ohms, min.
Isolator Limits		
	# Isolator modules per circuit	6 Maximum
	# Devices between two isolators	25 Maximum
	# Devices between panel and first isolator	25 Maximum
	# Devices between last isolator and panel (Class A)	25 Maximum
	Max. resistance from device to panel	25 Ohms
Maximum Wire Size		12 AWG (2.5 mm <sup>2</sup> )
Termination		Removable plug-in terminal strip on LRM
Operating Environment		32°F (0°C) to 120°F (49°C) 93% RH, non-condensing
Agency Listing		UL, ULC, CE, Complies with EN-54 parts 2 & 4, 1997

\*Note: Currents include full loop of devices

## Ordering Information

Catalog Number	Description	Shipping Wt., lb (kg)
3-AADC1	Addressable Analog Module	0.5 (.23)
3-RZBCAP	RZB Communications	
3-FP	Filler Plate, order separately when no LED or LED/Switch module installed.	0.1 (0.05)



**Detection & alarm since 1872**

**U.S.**

T 888-378-2329

F 866-503-3996

**Canada**

Chubb Edwards

T 519 376 2430

F 519 376 7258

**Southeast Asia**

T : +65 6391 9300

F : +65 6391 9306

**India**

T : +91 80 4344 2000

F : +91 80 4344 2050

**Australia**

T +61 3 9239 1200

F +61 3 9239 1299

**Europe**

T +32 2 725 11 20

F +32 2 721 86 13

**Latin America**

T 305 593 4301

F 305 593 4300

[utcfireandsecurity.com](http://utcfireandsecurity.com)

© 2010 UTC Fire & Security.

All rights reserved.

---